

**Canopy**  
**Mini Pure'line 90 cm**  
**Stainless steel**

EAN 5414425008209



### Energy label

▪ Energy Efficiency class (EEIhood)	A+
▪ Annual Energy Consumption (kWh/year) (AEChood)	29,1
▪ Fluid Dynamic Efficiency class (FDEhood)	A
▪ Lighting Efficiency class (LEhood)	A
▪ Grease Filtering Efficiency class (GFEhood)	D

### Functions & features

▪ Control method	Push buttons + Remote control
▪ Number of speeds	3 + power
▪ Automatic Power revert (minutes)	6
▪ Motor	Integrated
▪ Sound absorber	Integrated
▪ Recirculation	Optional
▪ InTouch function	Standard
▪ Auto stop	▪
▪ Delayed switch off (minutes)	10
▪ Number of grease filters	1
▪ Grease filter	7400020
▪ Grease filter cleaning indication	▪
▪ Recirculation filter cleaning indication	▪

### Dimensions

▪ Product dimensions (WxDxH) (mm)	860 x 301 x 330
▪ Width flange (mm)	10
▪ Dimensions cut-out opening (WxD) (mm)	845 x 286
▪ Min dimensions cabinet (WxDxH) (mm)	x x
▪ Advised mounting height induction hobs (Hmin-Hmax) (mm)	-
▪ Advised mounting height gas hobs (Hmin-Hmax) (mm)	650 - 850
▪ Advised mounting height ceramic hobs (Hmin-Hmax) (mm)	600 - 850
▪ Diameter outlet (mm)	150
▪ Position exhaust	Right, Top, Left, Back, Front

### Lighting

▪ Functional lighting type	Led
▪ Dimmable light	▪
▪ Soft-ON/OFF	▪
▪ Total energy consumption functional light (W)	8
▪ Color functional light	2700/4000

### Airflow and noise level

- Airflow (m<sup>3</sup>/h) measured according to EN 61591
- Sound regulation according to EN 60704-2-13

## Airflow and noise level

---

▪ Airflow speed 1 (m <sup>3</sup> /h) / Max Pressure speed 1 (Pa)	253 / 77
▪ Airflow speed 2 (m <sup>3</sup> /h) / Max Pressure speed 2 (Pa)	425 / 263
▪ Airflow speed 3 (m <sup>3</sup> /h) / Max Pressure speed 3 (Pa)	563 / 382
▪ Airflow Powerspeed (m <sup>3</sup> /h) / Max Pressure Powerspeed (Pa)	655 / 383
▪ Sound power speed 1 (dB(A)) / Sound pressure speed 1 (dB(A))	36 / 27
▪ Sound power speed 2 (dB(A)) / Sound pressure speed 2 (dB(A))	49 / 38
▪ Sound power speed 3 (dB(A)) / Sound pressure speed 3 (dB(A))	57 / 46
▪ Sound Powerspeed (dB(A)) / Sound pressure Powerspeed (dB(A))	60 / 49

## Technical specifications

---

▪ Maximum power	118
▪ Voltage (V)	220-230
▪ Frequency (Hz)	50
▪ Length power supply cord (m)	1,3
▪ Power consumption in stand-by-mode (Ps) (W)	0.29
▪ Net weight (kg)	14

1

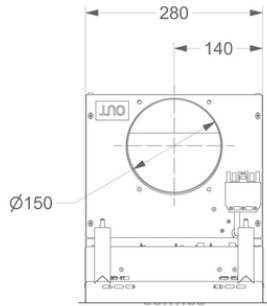

2

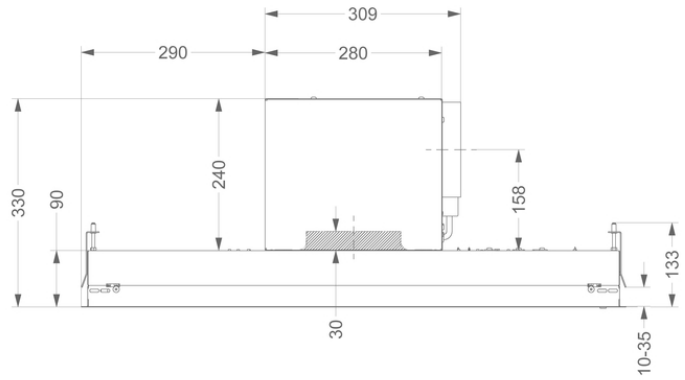

3

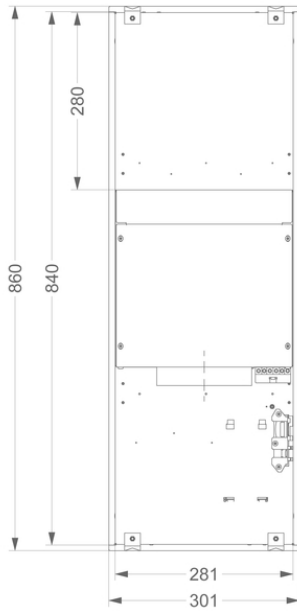

4

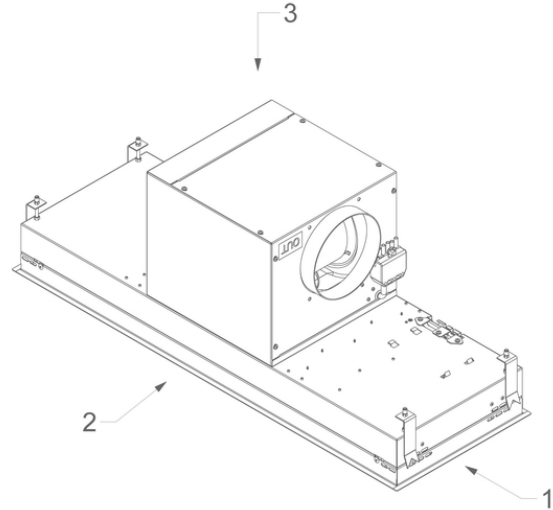

## Installation accessories

---

### Dissociated motor

- 800998

Kit to place motor at distance Mini Pure'line 820, 821, 826 (≥V15)

### Extension cable

- 700094

Extension cable 5 m

## Accessories

---

### Recirculation kit

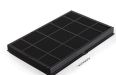

820400

Recirculation set Mini Pure'line 820, 821, 826

### Recirculation box



830400

recirculation box with monoblock stainless steel (270x500mm)



831400

recirculation box with monoblock white (270x500mm)



7900400

Recirculation box with monoblock stainless steel, height 140 mm

### Adapter for limited installation height



830052

Adapter limited installation height 18,3 cm

### Control kit



990030

Control kit for external lighting or valve

Efficiency Curve

